

Reg. No. :

--	--	--	--	--	--	--	--	--	--	--	--	--	--	--	--	--	--	--	--

Question Paper Code : 51226

B.E./B.Tech. DEGREE EXAMINATIONS, APRIL/MAY 2024.

Second Semester

Civil Engineering

GE 3251 – ENGINEERING GRAPHICS

(Common to All Branches) .

(Regulations 2021)

Time : Three hours

Maximum : 100 marks

Answer ALL questions.

(5 × 20 = 100)

1. (a) Construct a parabola when the distance between focus and the directrix is 40 mm. Draw tangent and normal at any point P on the curve. Use eccentricity method.

Or

- (b) An inelastic string of length 100 mm is wound around a circle of 25 mm diameter. Draw the path traced by the end of the string when the string is unwound around the circumference of the circle.

2. (a) A line AB, 90 mm long, is inclined at 30° to the HP. Its end A is 12 mm above HP and 20 mm in front of the VP. Its front view measures 65 mm. Draw the top view of AB and determine its inclination with the VP.

Or

- (b) A regular pentagonal lamina of 30 mm sides has one edge in HP and inclined at an angle of 30° to VP. Draw its projections when its surface is inclined at 45° to HP.

3. (a) Draw the projections of a cylinder, base 30 mm diameter and axis 50 mm long, resting with a point of its base circle on HP such that the axis is making an angle of 30° with HP and parallel to VP.

Or

(b) Draw the following orthographic views (Free hand sketch) of the figure shown below.

- (i) Elevation
- (ii) Right side view
- (iii) Plan

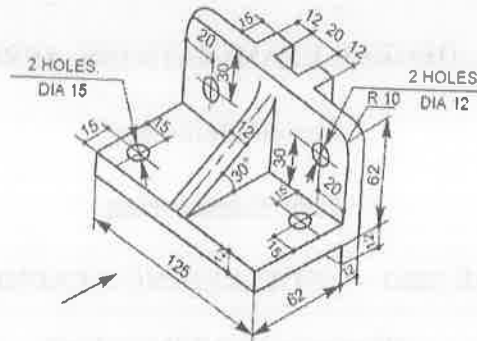

4. (a) A hexagonal pyramid, side of base 25 mm and altitude 70 mm long, rests with its base on HP with two of its base sides parallel to VP. It is cut by a section plane perpendicular to VP and inclined at 45° to HP and passing through a point 15 mm above the base and located on the axis. Draw the sectional top view and true shape of the section.

Or

- (b) A cone of base diameter 60 mm and height 70 mm is resting on its base on HP. It is cut by a plane perpendicular to VP and inclined at 30° to HP. The plane bisects the axis of the cone. Draw the development of its lateral surface.

5. (a) Draw the isometric projection of a hexagonal prism of side of base 30 mm and height 75 mm, when it is resting on HP such that an edge of the base is parallel to VP.

Or

- (b) A cylinder of diameter 40 mm and height 40 mm rests on the ground plane [GP] on one of its ends with its axis 35 mm behind the picture plane [PP]. The station point is 45 mm to the right of the axis. The station point is 65 mm above the GP and 40 mm in front of the PP. Draw the perspective view of the cylinder by visual ray method.